

FIRST IMPRESSION IS THE LAST
MAKE IT COUNT



CENTURY EXTERIA
Decorative Exterior Laminates

PRODUCT
CATALOGUE

VOL. 2

3853
GOTHIC MARBLE



03 ABOUT CENTURYPLY

05 CENTURYEXTERIA-AN OVERVIEW

07 SALIENT FEATURES

10 ARRAY OF APPLICATIONS

11 WOODGRAINS & STONES

23 FULL SHEET VIEW

41 SOLIDS

45 FIXATION SYSTEMS

47 PROJECTS

63 STORAGE & HANDLING

63 CARE AND MAINTENANCE

64 CERTIFICATIONS

65 DESIGN INDEX

66 SPECIFICATIONS

67 OUR PRESENCE

ABOUT CENTURYPLY

CenturyPly, the name that is the talk of the industry. A leader in varied plywood, decorative laminates and veneers, CenturyPly is a definite ruler in the Indian market. With a never-die attitude and customer satisfaction as the ultimate goal, CenturyPly is constantly researching, innovating and evolving its products to bring the best to its customers.

In 1986, two pioneering visionaries Mr. Sajjan Bhajanka and Mr. Sanjay Agarwal laid the foundation of Century Plyboards (India) Ltd. (CPIL), that is today generating millions in turnover and many more millions of satisfied customers in beautiful homes.

CenturyPly is the first choice of architects and interior designers – strongly recommending them to home makers across the country. Helping them transform mundane structures to pieces of beauty and comfort. As a brand that the world aspires to, we at CenturyPly believe in forging our way ahead through perseverance and determination. No wonder, every place we touch is transformed.





419
RECLAIMED WALNUT

CENTURYEXTERIA AN OVERVIEW

The world of CenturyExteria is the world of exterior grade, designer high pressure laminates that make the outside of any building, home or office, look as beautiful as the inside.

CenturyExteria promises the absolute best of exterior solutions in a wide array of designer shades, patterns and solids.

Exterior facades have a phenomenal impact on long term life and performance of a building. They directly influence the room and building temperature, impacting and lowering the energy use for cooling systems.

These uber cladding solutions from CenturyExteria are a definite mix of functionality, design optimization, and aesthetics. CenturyPly's own local manufacturing facility in India ensures that we have a strong logistic support ensuring that we unfailingly meet the project deadlines. Meant to create a lasting impression, CenturyExteria drapes building facades with both style and substance.

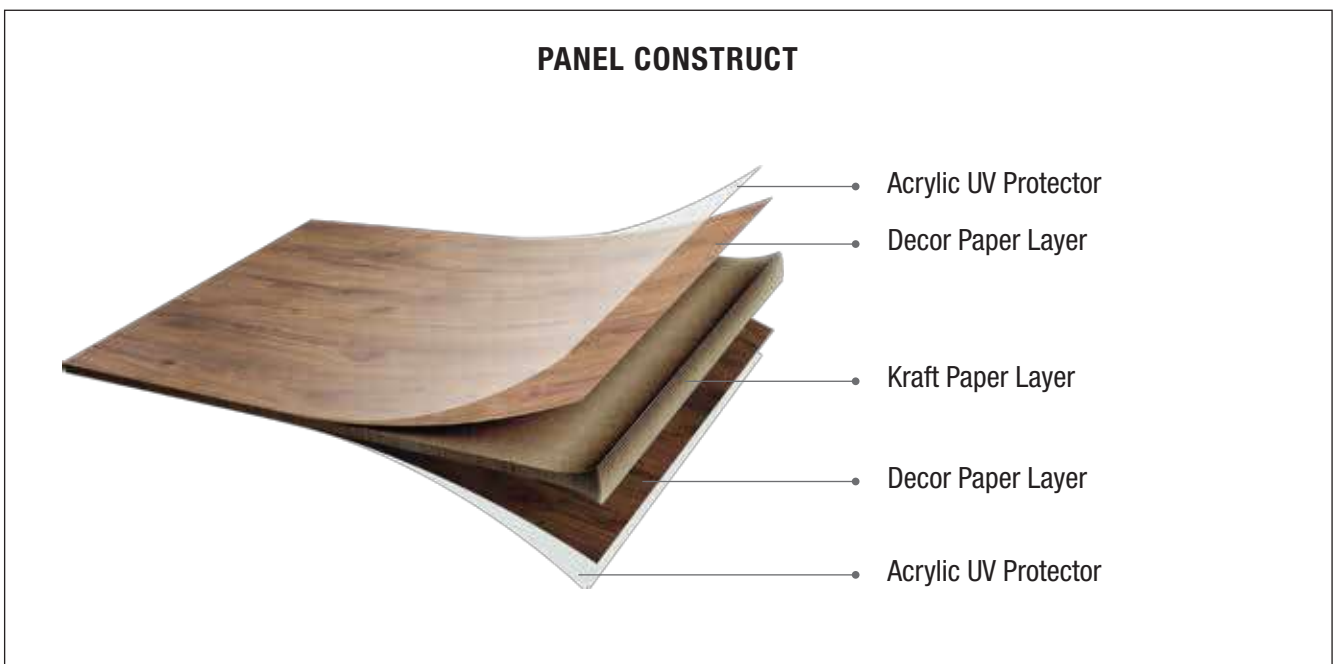



208
GLAZE YELLOW

181
VINTAGE BURGUNDY

SALIENT FEATURES

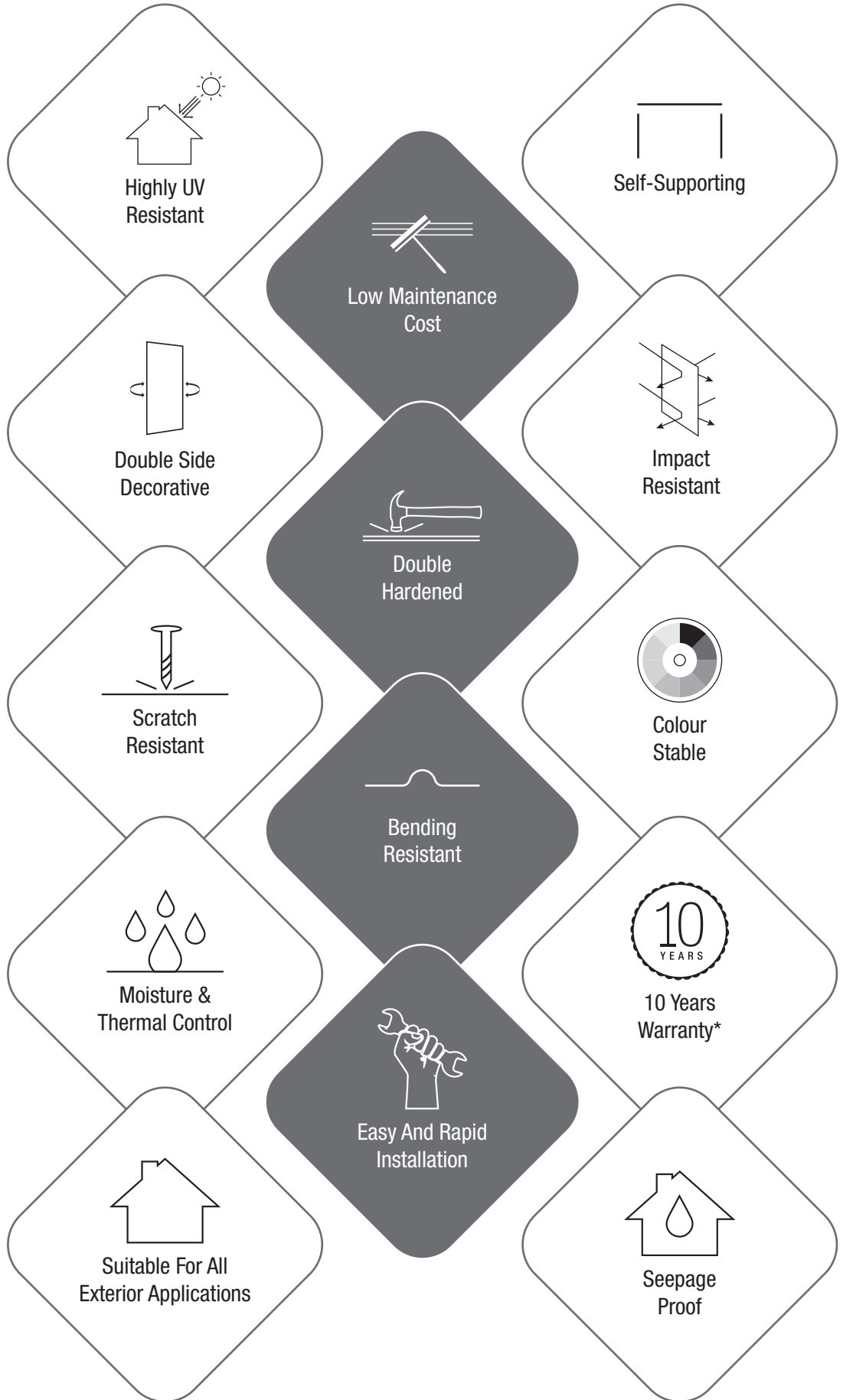

*Conditions apply

Ventilated Facade System

CenturyExteria panel cladding is a ventilated facade system that eliminates moisture problems due to internal condensation of water, ensuring an improved comfort for indoors. The drainage of rainwater, entering through the ventilation gaps between panels, is carried out through ventilation outlets. Another major benefit of CenturyExteria cladded walls is that they reduce the mechanical stress in the main structure; hence it is the most feasible solution for rehabilitation of aging building exteriors.



Fire Safety

CenturyExteria panels are having the property to reduce the fire spread intensity when it is exposed to fire and retain their stability for a long time. This has been tested and approved by authorised testing bodies in India and abroad. The CenturyExteria product falls within one of the most authentic fire retardant class ratings (Class - I), as per BS 476 Part#7. This product has also secured class - A rating as per ASTM E84 – 13a Std., with a F.S.I. value as 15 & S.D.I. as 350.



Tough

The suitable modulus of elasticity, high tensile and flexural strength make CenturyExteria panels highly impact resistant. The homogeneity in the composition and density of the core ensures high pull-out strength for fixings or fasteners, which is especially important when the panel is invisibly fixed with anchors. Not only this, the dimensional stability and workability of CenturyExteria panels are comparable to those of hardwood. These can be easily processed, cut, sized, drilled and perforated. These are also not affected by moisture and are not susceptible to weathering or rot.



Temperature Resistance

The CenturyExteria panel can withstand temperatures ranging from -20°C to +80°C, making it the most suitable exterior cladding option for any kind of climatic condition, whether it be chilling frosty weather or scorching heat.



Weather Protection

The specially designed weather-proof acrylic film on both sides of the panels are invincible against heavy rains, storms, harsh sunlight, scarring dusts and ensures indomitable protection against UV rays.



Colour Stability - Optimal Light Fastness

Colour stability of the vertically applied decorative surface of CenturyExteria panels comply with the highest score classification - 5 measured with the grey scale according to EN 438 - 6. The colours of CenturyExteria panels would have a very minimal effect (almost no considerable shade fading) in the most severe climatic conditions, under direct contact of UV rays and even in heavily polluted industrial locations.

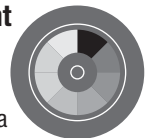

Acoustic Resistance

CenturyExteria panels have ventilated facade systems, which tend to influence the function of external noise reflection and behave as a sound insulating system (due to a high level of acoustic resistance of CenturyExteria panels), providing a considerable reduction in noise levels in commercial or institutional spaces like hospitals, office buildings, hotels and schools located in heavy traffic areas.



Thermal Insulation

Ventilated facade systems by CenturyExteria panels ensure natural ventilation and reduce the amount of heat that buildings absorb in hot weather. This helps in achieving a considerable reduction in air conditioning costs in summers, thereby proving to be an ideal exterior cladding solution with an attractively low payback period.





Roof cladding

Louvre

Highlighter

Gate cladding

ARRAY OF APPLICATIONS

Just like our sense of fashion reflects our taste, building facades too are an expression of individual style. CenturyExteria has various kinds of usage, only a few are mentioned below:

- Ventilated facade
- Fence, rail & screen
- Pedestrian shelter
- Duct covering
- Awning
- Partition
- Signage
- Lettering
- Kiosk
- Prefab hut
- Canopy
- Gate cladding
- Highlighter
- Louvre
- Roof cladding
- Soffit
- Balcony cladding
- Sliding shutter
- Parapet





WOODGRAINS & STONES

In love with nature?
Bring it to your doorstep.
Woodgrain facades bring
the beauty of a tree trunk
and the strength of stone
to the exterior of your
building.



WOODGRAINS & STONES



787
ZEBRA WOOD



3531
TYROL PINE



3408
PYRUS OSCURO



639
SUKUPIRA PRADO



784
WILD ZEBRANO



541
SAPELI



416
CRIANZA PEAR



464
NYANA TEAK



456
SAMOA TEAK



3594
BAVARIAN ASH GREY



3342
CLARO MAPLE

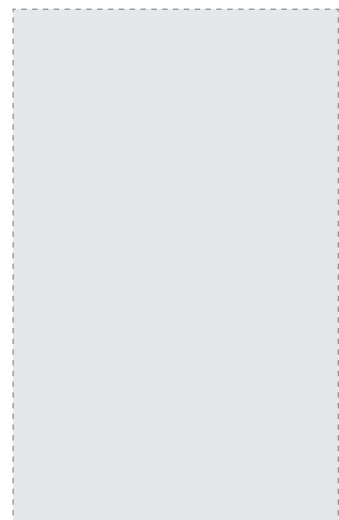

NEW
INTRO

WOODGRAINS & STONES



688
PRETTY WOOD



424
ERMANNNO WALNUT



3418
DECO WALNUT DARK BROWN



3419
DECO WALNUT LIGHT BROWN



3425
SAPWOOD WALNUT DARK BROWN



419
RECLAIMED WALNUT



494
NYANA ROSE

WOODGRAINS & STONES



321
CHERRY BEECH



468
MAHOGANY



4664
NAMIBIA OAK



4664
NAMIBIA OAK



3743
AFRICAN OAK NOIR



4641
OAK VALLEY LIGHT

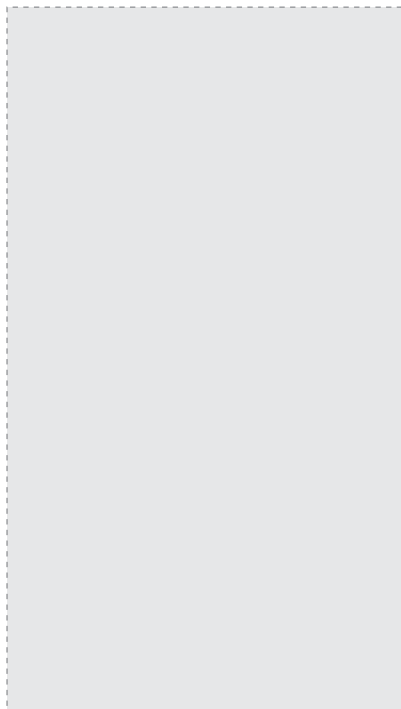

NEW
INTRO

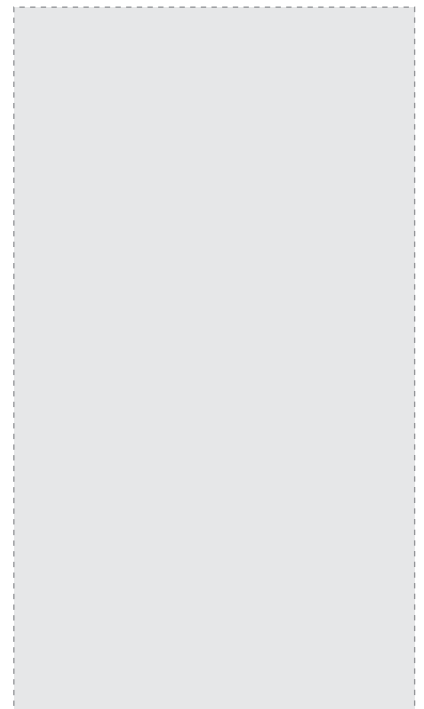

NEW
INTRO

WOODGRAINS & STONES



3802
PARDO REYRA



3802
PARDO REYRA



4655
KOHI VISGRAT



4656
GURE VISGRAT



3804
VERDE REYRA



3803
GRIS REYRA



3836
BARK STONE

WOODGRAINS & STONES



4867
TULA SILVER

3835
LAPIS AZUL



4867
TULA SILVER



3835
LAPIS AZUL



3854
SIERRA MARBLE



3846
WHITE MARBLE



3853
GOTHIC MARBLE



3852
SAGRADA MARBLE



3852
SAGRADA MARBLE

3853
GOTHIC MARBLE



FULL SHEET VIEW

The Full Sheet View gives a candid look into the intricate and voluminous patterns that adorn CenturyExteria. Have a closer look.



3408
PYRUS OSCURO | PAGE 13



639
SUKUPIRA PRADO | PAGE 13



3531
TYROL PINE | PAGE 13



784
WILD ZEBRANO | PAGE 13



541
SAPELI | PAGE 13



416
CRIANZA PEAR | PAGE 14



464
NYANA TEAK | PAGE 14



456
SAMOA TEAK | PAGE 14



3594
BAVARIAN ASH GREY | PAGE 14



3342
CLARO MAPLE | PAGE 14



787
ZEBRA WOOD | PAGE 13



688
PRETTY WOOD | PAGE 15



424
ERMANNNO WALNUT | PAGE 15



3418
DECO WALNUT DARK BROWN | PAGE 15



3419
DECO WALNUT LIGHT BROWN | PAGE 15



3425
SAPWOOD WALNUT DARK BROWN | PAGE 15



419
RECLAIMED WALNUT | PAGE 16



494
NYANA ROSE | PAGE 16



321
CHERRY BEECH | PAGE 17



468
MAHOGANY | PAGE 17



3743
AFRICAN OAK NOIR | PAGE 18



4664
NAMIBIA OAK | PAGE 18



4641
OAK VALLEY LIGHT | PAGE 18



3802
PARDO REYRA | PAGE 19



3803
GRIS REYRA | PAGE 20



3804
VERDE REYRA | PAGE 20



3836
BARK STONE | PAGE 20



4867
TULA SILVER | PAGE 21



3835
LAPIS AZUL | PAGE 21



4656
GURE VISGRAT | PAGE 20



3852
SAGRADA MARBLE | PAGE 22



3853
GOTHIC MARBLE | PAGE 22



3854
SIERRA MARBLE | PAGE 21



3846
WHITE MARBLE | PAGE 22



SOLIDS

Taking cue from the red blue and greens, solids add depth and dimension to otherwise flimsy exteriors. A dramatic way to give your facade character and strength.

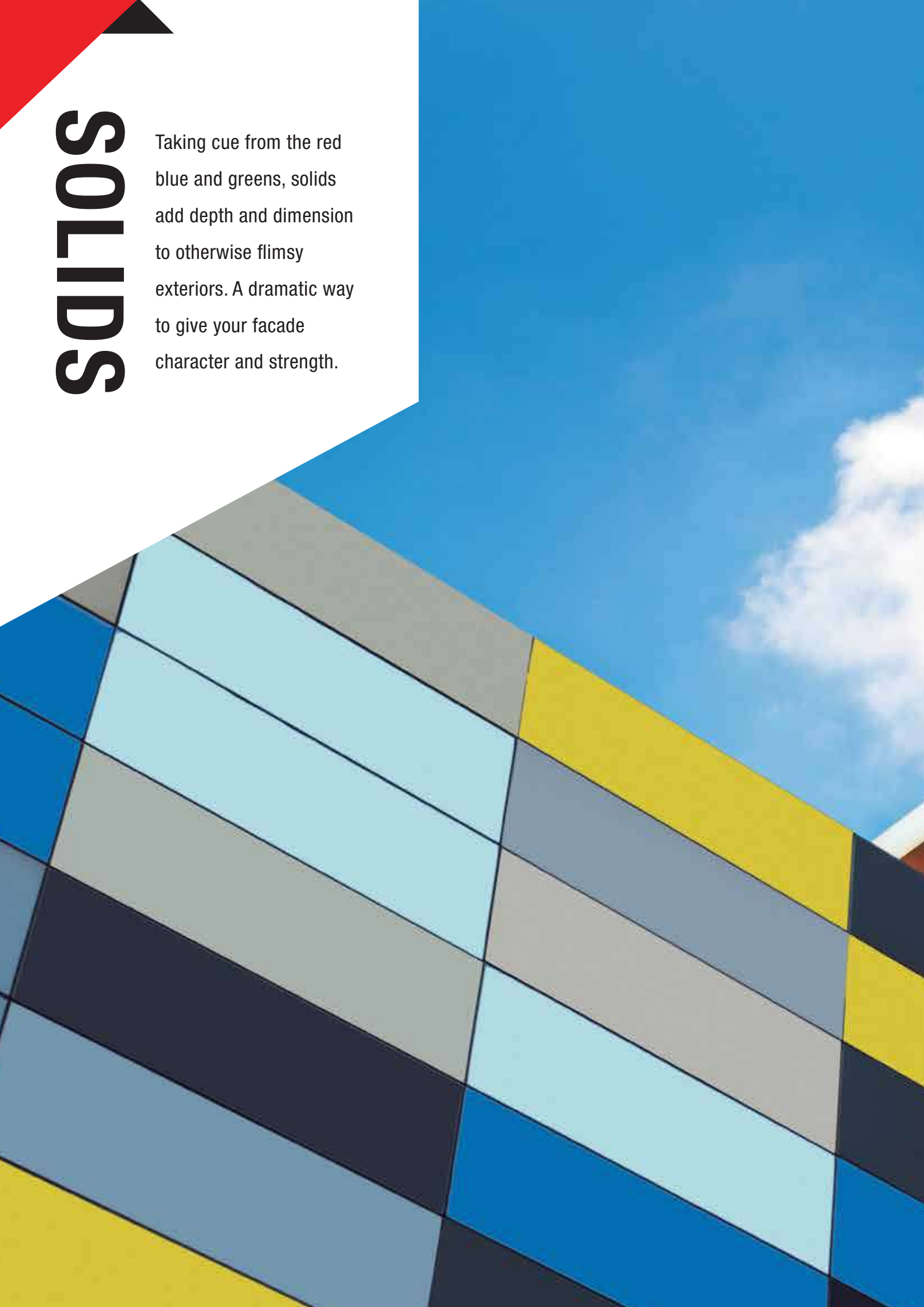



SOLIDS



101
WHITE

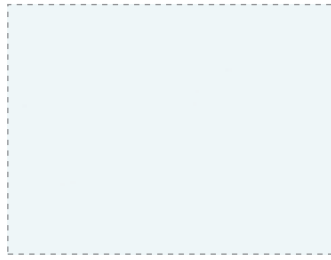

107
SNOW WHITE

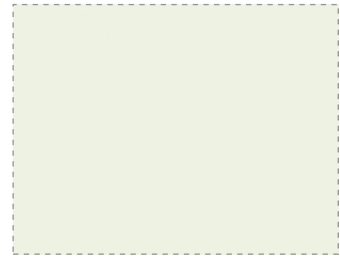

108
OFF WHITE



109
DESIGNER WHITE



121
IVORY



125
MYSORE IVORY

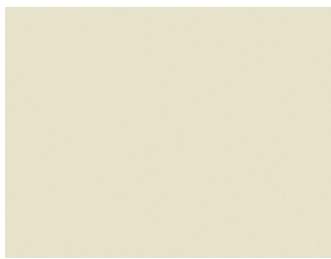

127
ALMOND IVORY



158
TAUPE



161
LIGHT BEIGE

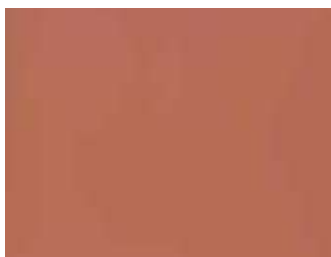

165
PEACH



172
MUDDY MUSHROOM

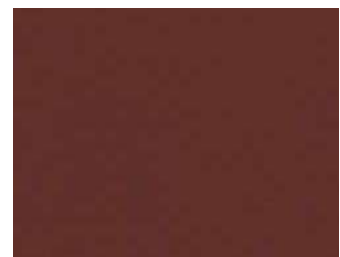

181
VINTAGE BURGUNDY



202
TAWNY



208
GLAZE YELLOW



209
EQUINOX YELLOW



221
LIGHT GREY



225
SILVER GREY



226
WARM GREY

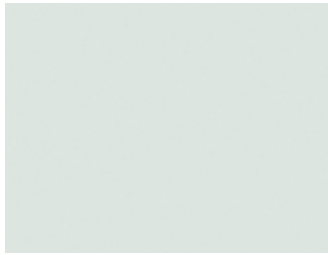

228
ALLU GREY



234
BLUISH GREY



238
GRAPHITE GREY

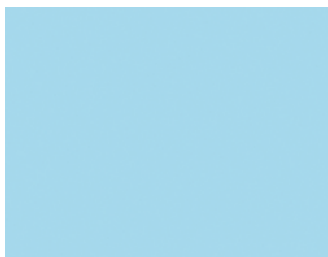

243
SKY BLUE



249
NAVY BLUE



259
DAWN BLUE

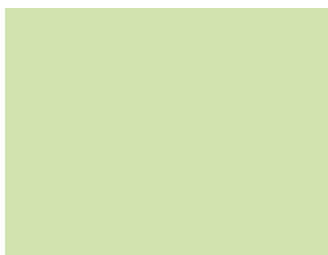

274
DESERT GREEN



276
PISTA GREEN



281
STEEL GREEN



287
HAWAIIAN GREEN

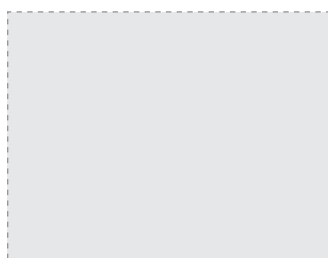

NEW
INTRO

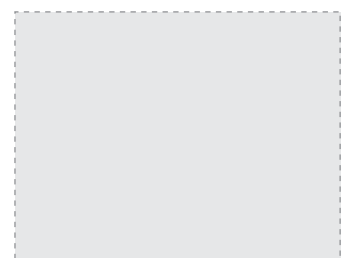

NEW
INTRO

FIXATION SYSTEMS

ADHESIVE FIXATION SYSTEM

Step1.
Assembling of M.S. galvanized bracket and fasteners on load bearing structure.



Max 600mm
Centre To Centre

Step2.
Assembling of S.S. nut bolt to lock aluminium extrusion from M.S. galvanized bracket and application of recommended primer.

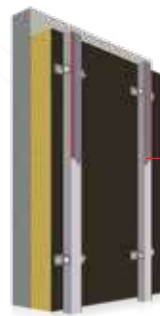

primer

Step3.
Application of recommended P.U. adhesive and VHB tape on primed surface of aluminium extrusion.

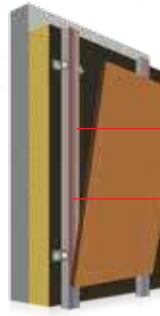

P.U. Adhesive
Double-sided Tape

Step4.
Panel fixing on aluminium frame.



panel

RIVET FIXATION SYSTEM

Step1.
Assembling of M.S. galvanized bracket and fasteners on load bearing structure

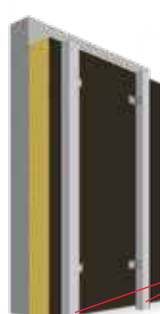

Max 600mm
Centre To Centre

Step2.
Assembling of S.S. nut bolt to fix aluminium extrusion with M.S. galvanized bracket.

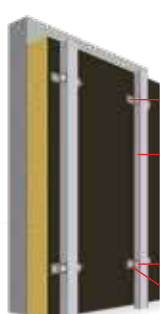

Fastener
Aluminium box Section
Nut/bolt (SS)
MS Galvanized bracket

Step3.
Detail of fixed point and sliding points on the panel.

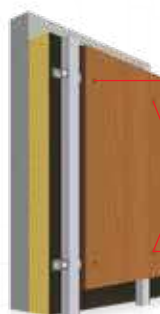

Fixed Point
Sliding Point
Rivets

Step4.
Fixing of coloured aluminium rivet on the panel.

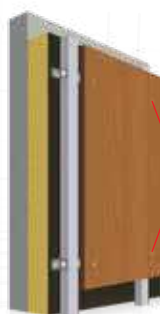

Coloured Aluminium Rivets

OTHER FIXATIONS

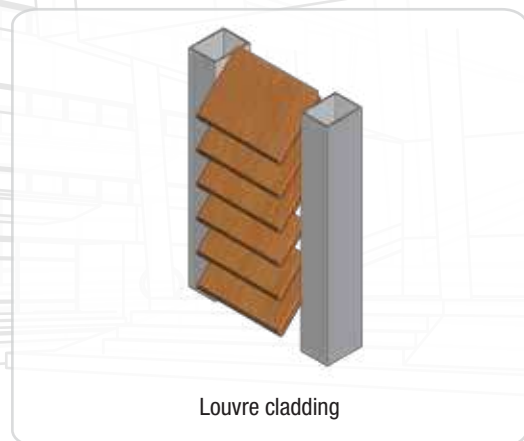
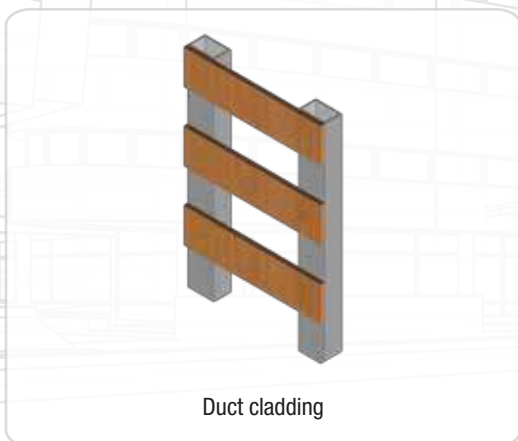
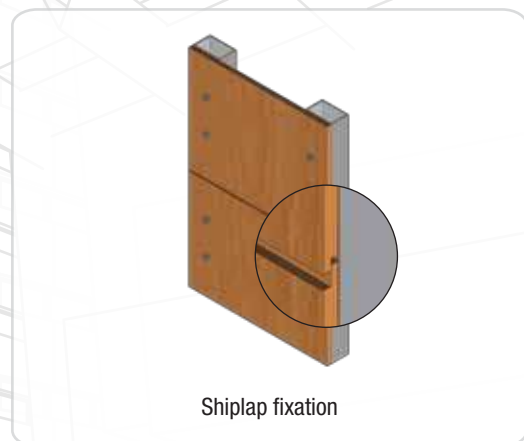
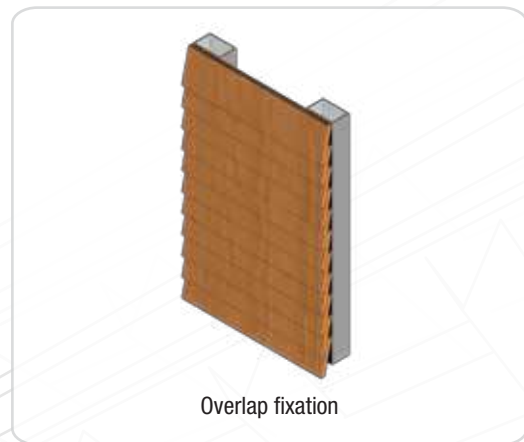
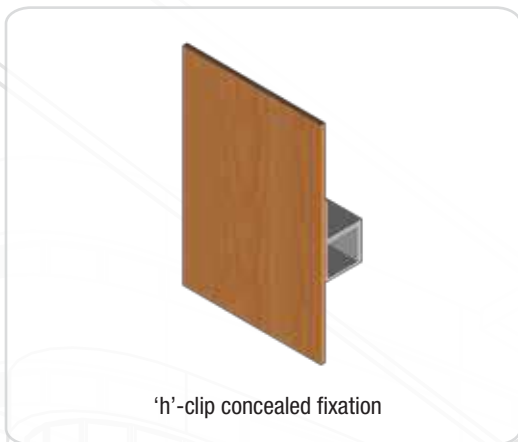
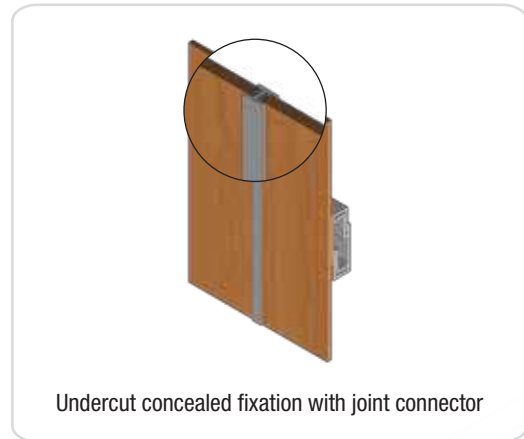
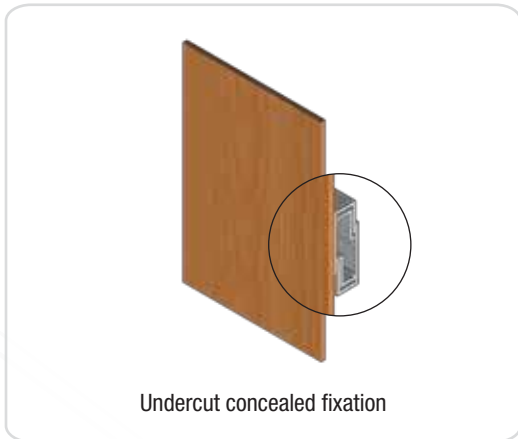

PROJECTS

CenturyExteria has done some of the most remarkable projects in the commercial and residential sectors. CenturyExteria has brought about a fabulous transformation in not only the projects it is used in but the landscapes they highlight.





3531
TYROL PINE

Commercial

1-2. State Bank of Mysore | Bangalore
3-4. Swarna Mahal Jewellery | Bangalore

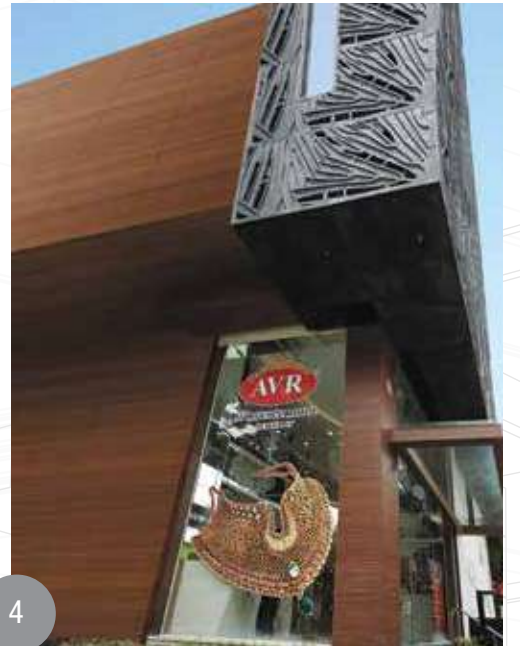

5-6. Karur Vaishya Bank | Bangalore

7-8. NU Hospital | Bangalore



7



8



9



9-10. Our Lady of the Sacred Heart Church | Bangalore

10



11

11-12. Purvankara Ltd. | Bangalore



12



13



14



15



16

13-14. Temple School | Chennai

15-16. Sree Varaham Hall | Chennai



17



18

17-18. DRR Hospital | Chennai

19-20. Merlin Infinite | Kolkata
21-22. PC Chandra Jewellers | Kolkata

19



20



21



22



23



23-24. Aspirations Accent | Kolkata

24



26

25-26. Mahaba Mall | Shillong

25



27-28. Smart Shopping Complex | Hisar

27

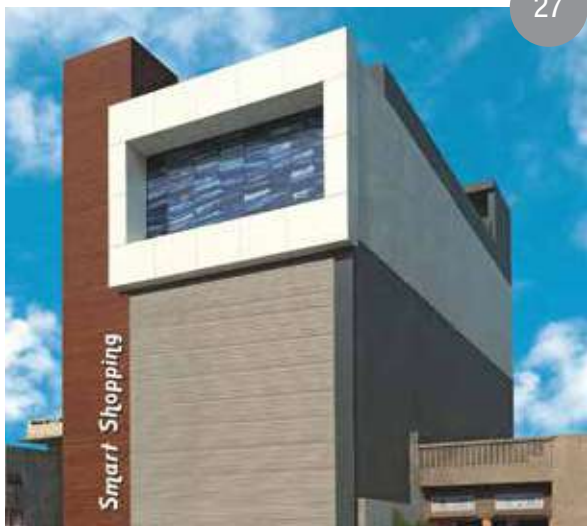

28

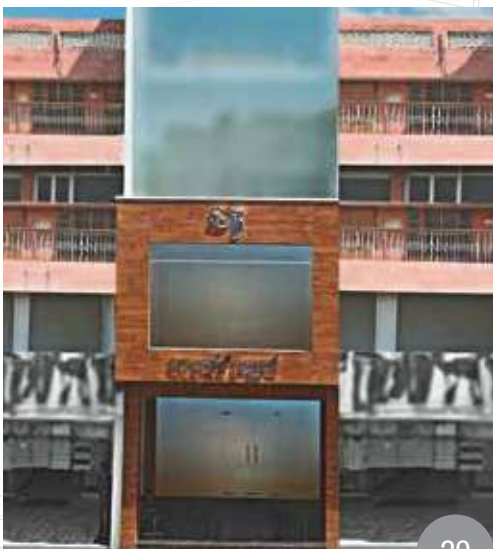

29



30

29-30. Saraswati Jewellers | Hisar

31-32. Kohli Realtor's Office Space 1 | Delhi

33-34. Kohli Realtor's Office Space 2 | Delhi



35-36. Amrit Hospital | Moga

Residential

38

37-38. Bungalow at Koramangla | Bangalore

39-40. Bungalow at Domlur | Bangalore



37



39



40



41

41-42. Shriram Smrithi Residency | Bangalore



42

43-44. Sri Rajalakshmi Kuteera | Bangalore

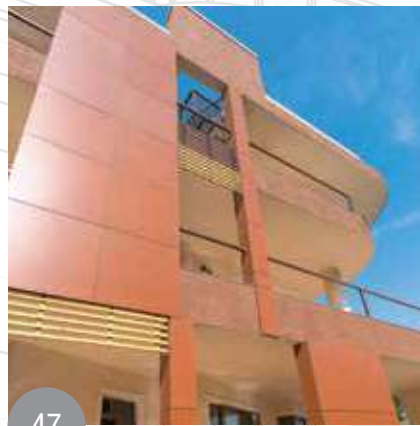
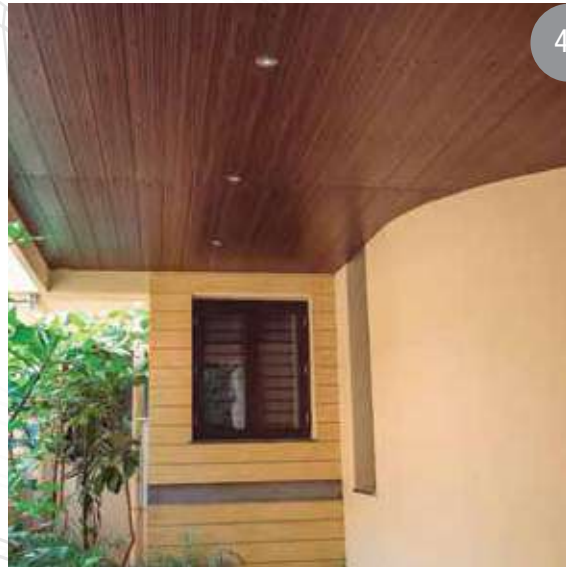

45-46. Ostraca Residency | Bangalore

47-48. Elegant Exotica | Bangalore

49



50



49-50. Bungalow at Nuganbakkam | Chennai
51-52. Bungalow at Kilpauk | Chennai



51

52



54

53



53-54. Beach House at Neelankarai | Chennai

55. Apartment at Perus Garden | Chennai
56. Bungalow at Annanagar | Chennai

55

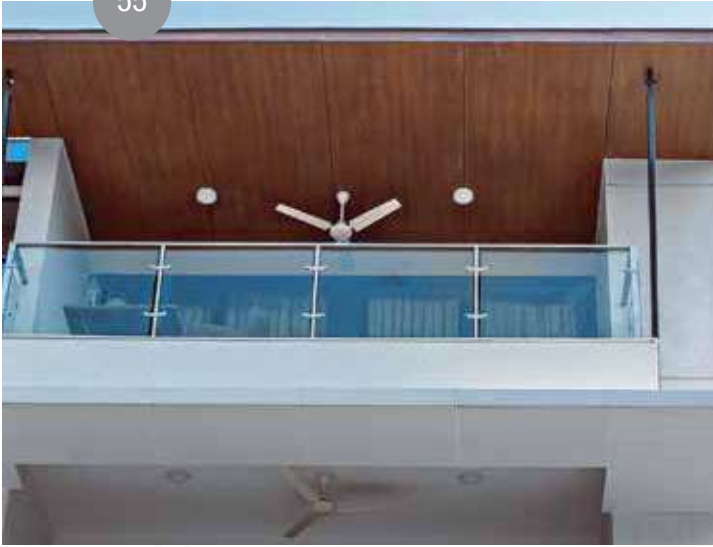

56



58

57-58. ARR Foundation | Chennai

57

59

59-60. Bungalow at Salt Lake | Kolkata



60



61



62



63



64

61-62. Apartment at Sunny Park | Kolkata

63-64. Fort Legend | Kolkata

65-66. Bungalow at GK - I | Delhi



65



66

67-68. Bungalow at Shakti Vihar | Delhi

67



68

69



70



71



69-70. Bungalow at Sushant Lok - I | Gurugram

71-72. Farm House at Chhattarpur | Delhi



72

74

73-74. Bungalow at GK - I | Delhi
75-76. Bungalow at Sushant Lok - II | Gurugram

73



75



76



77

77-78. Bungalow at GK - I | Delhi



78

80

79-80. Bungalow at Green Avenue | Amritsar



79



82



81-82. Bungalow at Haibowal | Ludhiana

83-84. Bungalow at Huda Sector - 17 | Hisar

81



84



83



STORAGE & HANDLING

- Store in a dry, clean, frost-free room.
- CenturyExteria HPL sheets must be stacked horizontally.
- A levelled surface which provides full and uniform support to the pallets on which CenturyExteria HPL sheets are placed during storage, should be made available.
- Dirt, dust or any abrasive material in any form must always be avoided on or between CenturyExteria HPL sheets.
- Keep CenturyExteria HPL sheets in the original, closed packaging where possible.
- Do not place any moisture-sensitive separator layers between the CenturyExteria HPL sheets. If required, use plastic sheets as intermediate layer.
- Treat CenturyExteria HPL sheets with care. Suitable protective hand gloves must always be worn while handling.
- CenturyExteria HPL sheets should not be slid over another or pushed/pulled over edge while they are being carried or loaded. During transportation always lift the sheets.
- The peel off film should be ideally removed within 14 days of installation of the panels.

CARE AND MAINTENANCE

- CenturyExteria HPL panel surfaces can be cleaned with a damp cloth and mild detergent (baby shampoos, liquid dish washing detergents, liquid soaps etc.). After cleaning, a thorough rinsing and drying is required.
- Any kind of abrasive cleaner, powder, scouring pad, steel wool, chisel, sandpaper, brush having hard rigid bristles etc. should never be used; this can leave permanent scratch marks on the laminate and irreversibly damage the finish.
- Don't use any strongly acidic or alkaline based solvent, bleach, heavily chlorinated product or furniture polish as cleaning agent; these agents can discolour the UV protective film on the panel.
- Any solvents having polyurethane lacquer, paint thinner and nail polish remover must not be used, as these solvents can have adverse effects on the UV protective film.

Note: Any kind of improper or incorrectly performed cleaning will make the warranty void.

Green Credentials

CERTIFICATIONS OF COMPLIANCE



**CENTURY
PLYBOARDS
(INDIA) LIMITED**

**CenturyLaminates Exterior
Grade Compact**

Certificate Number
17649-410

Status
Certified

UL 2818 - 2013 Standard for Chemical Emissions for Building Materials, Finishes and Furnishings

Building materials are determined compliant in accordance with an Office environment with an air change of 0.68 hr-1 and a loading of 3.20 m2. Products tested in accordance with UL 2821 test method to show compliance to emission limits in UL 2818, Section 7.1



Environment

UL Environment investigated representative samples of the identified Product(s) to the identified Standard (s) or other requirements in accordance with the agreements and any applicable program service terms in place between UL Environment and the Certificate Holder (collectively "Agreement"). The certificate Holder is authorized to use the UL Environment Mark for the identified Product(s) manufactured at the production site(s) covered by the ULE Test Report, in accordance with the terms of the Agreement. This Certificate is valid for the identified dates unless there is non-compliance with the Agreement.



**The mark of
responsible forestry**

* FSC certified products are available on request.

INDEX

Design No.	Design Name	Page No.
321	CHERRY BEECH	17
416	CRianza PEAR	14
419	RECLAIMED WALNUT	16
424	ERMANN0 WALNUT	15
456	SAM0A TEAK	14
464	NYANA TEAK	14
468	MAHOGANY	17
494	NYANA ROSE	16
541	SAPELI	13
639	SUKUPIRA PRADO	13
688	PRETTY WOOD	15
784	WILD ZEBRANO	13
787	ZEBRA WOOD	13
3342	CLARO MAPLE	14
3408	PYRUS OSCURO	13
3418	DECO WALNUT DARK BROWN	15
3419	DECO WALNUT LIGHT BROWN	15
3425	SAPWOOD WALNUT DARK BROWN	15
3531	TYROL PINE	13
3594	BAVARIAN ASH GREY	14
3743	AFRICAN OAK NOIR	18
3802	PARDO REYRA	19
3803	GRIS REYRA	20
3804	VERDE REYRA	20
3835	LAPIS AZUL	21
3836	BARK STONE	20
3846	WHITE MARBLE	22
3852	SAGRADA MARBLE	22
3853	GOTHIC MARBLE	22
3854	SIERRA MARBLE	21
4641	OAK VALLEY LIGHT	18
4655	KOHI VISGRAT	19
4656	GURE VISGRAT	20
4664	NAMIBIA OAK	18
4867	TULA SILVER	21

Technical data sheet

EXTERIOR GRADE HIGH PRESSURE COMPACT LAMINATE

Size: 2440 mm. x 1220 mm.

Sl. No.	EDF Grade Specification		CenturyExeria EDF (Non Halogenated)
	Properties	As per EN 438-part 6	
1	Thickness (mm.)		
	$5.00 \leq t < 8.00$ mm.	6.00 ± 0.40 mm.	6.00 ± 0.40 mm.
2	Length (mm.)	$2440.00^{+10.00 \text{ mm} / - 0.00 \text{ mm}}$	$2440.00^{+10.00 \text{ mm} / - 0.00 \text{ mm}}$
3	Width (mm.)	$1220.00^{+10.00 \text{ mm} / - 0.00 \text{ mm}}$	$1220.00^{+10.00 \text{ mm} / - 0.00 \text{ mm}}$
4	Max. Edge Straightness (mm.)	1.50 mm. / m.	≤ 1.00 mm. / m.
5	Max. Edge Squareness (mm.)	1.50 mm. / m.	≤ 1.00 mm. / m.
6	Max. Flatness (mm.)		
	$6.00 \leq t < 10.00$ mm. (t = nominal thickness)	5.00 mm. / m.	≤ 5.00 mm. / m.
	$t \geq 10.00$ mm.	3.00 mm. / m.	≤ 3.00 mm. / m.
7	Flexural Modulus (Min.)	9000 M Pa	$\geq 11,000$ M Pa
8	Flexural Strength (Min.)	80 M Pa	≥ 100 M Pa
9	Tensile Strength (Min.)	60 M Pa	≥ 70 M Pa
10	Density, gm. / cm ³ (Min.)	1.35 gm. / cm ³	1.45 gm. / cm ³
11	Resistance to impact by large diameter ball		
	a) Drop height, mm. (Min.)		
	$t \geq 5.00$ mm. (t = nominal thickness)	1800.00 mm.	2000.00 mm.
	b) Indentation Dia., mm. (Max.)	10.00 mm.	≤ 10.00 mm.
12	Resistance to wet conditions		
	a) Mass increase % (Max.)		
	$t \geq 5.00$ mm. (t = nominal thickness)	8%	3%
	b) Appearance (not worse than)	Rating 4	Rating ≥ 4
13	Dimensional stability at elevated temperature		
	$t \geq 5.00$ mm.		
	a) Longitudinal, % (Max.)	0.30%	$\leq 0.20\%$
	b) Transverse, % (Max.)	0.60%	$\leq 0.40\%$
14	Resistance to climatic shock		
	a) Appearance	Rating 4	Rating 4
	b) Flexural Strength Index (Min.)	0.95	≥ 0.95
	c) Flexural Modulus Index (Min.)	0.95	≥ 0.95
15	Resistance to artificial weathering (including Light Fastness)	After 650 MJ / m ² radiant exposure (3000 hrs.)	3000 hrs. passes
	a) Gray scale rating (not worse than)	Rating 3	Rating 5
	b) Appearance (Min.)	Rating 4	Rating 5
16	Resistance to UV light	After 1500 hrs. exposure	1500 hrs. passes
	a) Gray scale rating (not worse than)	Rating 3	Rating 5
	b) Appearance (Min.)	Rating 4	Rating 5
17	Spread of flame	Class 1	Class 1
Standard : ASTM E84			
18	Classification	Class	Class A
	Flame Spread Index	FSI 0 - 25	<25
	Smoke Developed Index	SDI 0 - 450	<450

Remark: E - Exterior Grade, D - Severe Use, F - Flame Retardant.

OUR PRESENCE

HEAD OFFICE

Sumit Roy
Century House
P 15/1, Taratala Road,
Kolkata-700088
Ph. (033) 3940 3950
E. sumit.roy@centuryply.com

EAST

KOLKATA

Sayantana Saha, M 7856976956
First Floor, 6 Lyons Range, Kolkata-700001
Ph. (033) 3940 3950
E. sayantan.saha@centuryply.com

BHUBANESHWAR

Sayantana Saha, M 7856976956
Plot No. 40 & 41, Bomikhakli, Rasulgarh,
NH-5, Khordha, (Near Narayani Motor
Lines In front of Image)
Bhubaneswar-751010 (Odisha)
Ph. (0674) 3270189, 2582502
E. sayantan.saha@centuryply.com

PATNA

Faridul Beg, M 7044169544
Ground Floor, Shivkunj Apartment,
Behind Chandi Vyapar Bhawan,
Exhibition Road, Patna-800001
Ph. (0612) 3210071
E. foridul.beg@centuryply.com

RANCHI

Faridul Beg, M 7044169544
Mahadev Path, DAV School Road,
Near Kathalmore, Post-Lalghutwa, Ranchi-834005
Ph. (0651) 2525417, 3245541
E. foridul.beg@centuryply.com

WEST

MUMBAI

Sandesh Yerunkar, M 8291624157
1501-1506, Range Heights,
15th Floor, Link Road, Oshiwara,
Behram Baug, Jogeshwari-West
Mumbai-400102
Ph. 9920801730 Fax: (022) 39403950
E. sandesh.yerunkar@centuryply.com

PUNE

Sambit Kumar Das, M 7972567835
Office No. 402, Winners Court
4th Floor, Above ZK's Restaurant
Lulla Nagar Chowk, Pune-411040
Ph. (020) 26831140 Fax: (020) 24471140
E. sambitk.das@centuryply.com

NAGPUR

Sambit Kumar Das, M 7972567835
202 Crystal Plaza,
276 Central Bazar Road,
Ramdaspath, Nagpur-440023 (M.S.)
Ph. (0712) 3223921, 3223922
E. sambitk.das@centuryply.com

INDORE

Sambit Kumar Das, M 7972567835
2nd Floor, R/D, Bajaj Nagar
(Above Vodafone Gallery), Nagpur - 440010
Ph. (0731) 3228122, 3221621
E. sambitk.das@centuryply.com

AHMEDABAD

Puneet Kumar, M 9811711522
1006-1009, Sakar III, 10th Floor
Near Income Tax Circle
Ashram Road, Ahmedabad-380014
Ph. (079) 39403950 Fax: (079) 27540900
E. puneet.k@centuryply.com

SURAT

Puneet Kumar, M 9811711522
305, Royal Trade Center,
Third Floor, Opp. Star Bazar,
Adajan, Surat-395009
E. puneet.k@centuryply.com

NORTH

DELHI

Abhishek Kumar
M 9073388461, 9811711522
5/2, D B Gupta Road,
Rajnigandha Building, 2nd Floor
Room No.203, Paharganj, New Delhi-110055
Ph. (011) 30122948, 30122958
Fax: (011) 30122949
E. abhishek.kumar@centuryply.com

GHAZIABAD

Vinay Sharma
M 9599114493, 9811711522
C 21, Meerut Road Industrial Area,
Near DPS School, Ghaziabad-201003 (U.P.)
Ph. (0120)3140921, 3141322,4205605
E. vinay.sharma@centuryply.com

LUCKNOW

Puneet Kumar, M 9811711522
E/1-139 Phase 2, Opposite Parking No 07,
Transport Nagar, Lucknow-226012
E. puneet.k@centuryply.com

LUDHIANA

Anish Tiwari, M 9803003334
Shop No.-58, 1st Floor, New Grain Market,
Gill Road, Dana Mandi,
Ludhiana (Punjab)-141003
Ph. (0161) 5059825, 50561025, 505702
E. anish.tiwari@centuryply.com

SOUTH

BANGALORE

Sabyasachi Barik, M 9620077781
#92, 3rd Floor, HJS Chamber,
Next To Pride Hotel, Richmond Road
Bangalore-560025
Ph. (080) 39403950
E. sabyasachi.barik@centuryply.com

COIMBATORE

G Chandrasekaran, M 9176669049
No. 169/1C, Goundaiyan Thottam,
Appanaicken Palayam, K-Vadamadurai Post,
Coimbatore-641017
Ph. (0422) 9025844135, 7601805123
E. g.chandrasekaran@centuryply.com

CHENNAI

G Chandrasekaran, M 9176669049
2/1 First Floor, Sattana Naciken Street,
Inside Nehru Timber Market Choolai,
Chennai-600112
Ph. (044) 30544500 Fax: (044) 26692455
E. g.chandrasekaran@centuryply.com

HYDERABAD

Abhilash Kumar, M 7799844495
No. 405A, Minerva Commercial Complex
Near Paradise Junction, SD Road,
Secunderabad-500003
Ph. (040) 39403950
E. abhilash.kumar@centuryply.com

KOCHI

R. Rajesh Kumar, M 9620045669
24-B Alakalathil Building, Ground Floor,
Marottichuvadu, Edapally PO, Kochi-682024
E. r.rajeshkumar@centuryply.com

Flip for the product sample





Product Sample, 6mm

CenturyExteria is also available in 4mm, 8mm, 12mm and upto 15mm thickness

A quality product from  **CENTURYPLY**[®]



CENTURYEXTERIA
Decorative Exterior Laminates

Century Plyboards (India) Ltd

CENTURY HOUSE

P 15/1, Taratala Road, Kolkata-700088

T 033 3940 3950

E exteria@centuryply.com | W www.centuryexteria.com

 [CenturyPlyOfficial](#)  [Centuryply1986](#)  [CenturyPlyIndia](#)

Please call our customer executive at 1800-5722-122